

**OFFICE OF BRIDGE DEVELOPMENT
MANUAL FOR HYDROLOGIC AND HYDRAULIC
DESIGN**

CHAPTER 11, EVALUATING SCOUR AT BRIDGES

APPENDIX D

**SCOUR COUNTERMEASURES
FOR
PIERS AND ABUTMENTS**



APRIL 2004

CHAPTER 11 EVALUATING SCOUR AT BRIDGES

TABLE OF CONTENTS

11D-1.0 INTRODUCTION.....	3
11D.2.0 POLICY.....	3
11D.3.0 DESIGN OF RIPRAP INSTALLATIONS.....	4
11D.4.0 REFERENCES.....	6
ATTACHMENT 1 DETAILS OF TYPICAL RIPRAP INSTALLATIONS AT PIERS AND ABUTMENTS.....	7
ATTACHMENT 2 EXCERPTS FROM FHWA HEC-23, DESIGN GUIDELINE 8, ROCK RIPRAP AT PIERS AND ABUTMENTS.....	12

CHAPTER 11, EVALUATING SCOUR AT BRIDGES
APPENDIX D
SCOUR COUNTERMEASURES AT PIERS AND ABUTMENTS

11D-1.0 INTRODUCTION

On September 16, 1993, the Office of Bridge Development issued a guideline entitled “Draft Guidelines for Designing Scour Countermeasures at Bridges”. This document has served as the primary guide of the Office of Bridge Development for the design of riprap at bridges. Appendix D serves to update and supercede the 1993 Draft Guidelines.

The FHWA Hydraulic Engineering Circulars (See References) serve as the primary technical references for the information in this Appendix. In particular, Hydraulic Engineering Circular 23, “Bridge Scour and Stream Instability Countermeasures” consists of an entire manual devoted to scour countermeasures. Engineers are encouraged to use these FHWA Manuals to gain insight into the factors to be considered in the design of scour countermeasures.

Appendix D sets forth the policies and practices of the Office of Bridge Development regarding scour protection at new bridges. For most locations, this scour protection will consist of Class 2 or Class 3 riprap. If the Engineer believes that some other type of scour countermeasure is more appropriate for a given location, he or she should discuss such ideas with the Structures Hydrology and Hydraulics Unit (H&H) prior to commencing design on the scour countermeasure.

The Bridge Inspection and Remedial Engineering Section (B.I.R.E.) has the primary responsibility for installing scour countermeasures at existing bridges. Designing countermeasures for existing bridges, as compared with new bridges, often involves a different set of conditions and solutions. Therefore, such countermeasures are not considered in this Appendix. The Structures Hydrology and Hydraulics Unit often works with B.I.R.E. through the Interdisciplinary Scour Team to evaluate scour countermeasures at existing bridges on a case by case basis.

11D.2 POLICY

The primary objective of the Office of Bridge Development is to provide for the safety of the traveling public. Scour countermeasures serve as an important design features to assure the stability of a bridge to resist damage from scour. The bridge, taking into consideration the protection afforded by scour countermeasures, should be designed to withstand worst-case scour conditions. Early coordination is necessary with environmental and regulatory review agencies to make them aware of proposed scour countermeasures. Designs for scour countermeasures should be included in submittals for necessary permits.

11D.2.1 ABUTMENTS

- Design abutment foundations in accordance with the provisions of Chapter 11.
- Provide a riprap or other scour countermeasure at every abutment. If there are field conditions which render the scour countermeasure unnecessary, this condition should be supported in the scour report.
- Use Class 2 or larger riprap; place riprap to a minimum depth of 6 feet in the toe section on the flood plain or channel. Section 11D.3 permits an exception to this policy for certain field conditions.
- Abutment protection for existing bridges should be designed in accordance with design criteria used by Bridge Inspection and Remedial Engineering.

11D.2.2 PIERS

- Piers for new bridges are to be designed to be stable for anticipated worst-case conditions of scour without reliance on scour countermeasures.
- In the event that a riprap installation is determined to be necessary for a new bridge, the installation should be designed in accordance with the details presented in Section 11D.3.
- Pier protection for existing bridges should be designed in accordance with design criteria used by Bridge Inspection and Remedial Engineering.

11D.3.0 DESIGN OF RIPRAP INSTALLATIONS

11D.3.1 GENERAL

It is the experience of engineers in the SHA Office of Bridge Development that Class 2 riprap (D50 = 16 inches) serves satisfactorily as scour protection for most non-tidal bridge sites. Class 3 riprap (D50 = 23 inches) requires a thicker blanket and is usually more costly than Class 2 riprap. However, use of Class 3 riprap is necessary in some cases to withstand high velocity flows.

Class 1 riprap is not generally recommended for use for scour protection for bridges. There are certain conditions where Class 1 riprap may be considered for bridges on flood plains where flow depths and velocities are low for worst-case scour conditions. These conditions are described in Figure 4.

Special design procedures are required for the analysis of riprap installations to resist wave action. These procedures are discussed in Section 11D.3.5 below.

11D.3.2. SELECTION OF THE RIPRAP D50 SIZE AND BLANKET THICKNESS

The FHWA equations from HEC-23, Bridge Scour and Stream Instability Countermeasures (Design Guideline 8, Rock Riprap at Abutments and Piers) should be used to compute the minimum required D50 size of riprap (Attachment 2). This value is to be compared with the D50 size of riprap in Table 1 below to select the appropriate

riprap Class and blanket thickness. As noted previously, use of Class 1 riprap is not recommended except for certain conditions as set forth in Figure _4.

TABLE 1
SELECTION OF THE RIPRAP D50 SIZE AND BLANKET THICKNESS

RIPRAP CLASS	D50 MINIMUM SIZE (INCHES)	APPROXIMATE D50 WEIGHT (POUNDS)	MINIMUM BLANKET THICKNESS (INCHES)*
I	9.5	40	19
II	16	200	32
III	23	600	46

* These dimensions apply to the upper blanket section only, not the toe section

11D.3.3. DESIGN OF THE TOE SECTION

A stable riprap toe is the most important feature in the design of riprap abutment protection installations. Guidance on the design of the toe section is provided in Figure 1. The following criteria serve to establish the design for the riprap toe:

1. Design the riprap toe to extend below the depth of contraction scour in the scour cross-section (See Figure 1).
2. The riprap toe should be at least 6 feet thick. (A lesser toe thickness may be appropriate under certain field conditions as depicted by Figure 4.)
3. The top width of the riprap toe is typically 12 feet or more in order to fit the riprap geometry to the ground conditions.
4. An aggregate or geotextile filter cloth is normally used with the riprap installation.

11D.3.4 RIPRAP SPECIFICATIONS

The following riprap specification are set forth in the January 2001 Edition of the SHA Standard Specifications for Construction and Materials:

Construction: Section 312, Riprap Slope and Channel Protection

Materials: Section 901.01, Aggregate Filter Blanket; 901.02 Stone for Riprap; 921.09 Geotextile.

11D.3.5. RIPRAP INSTALLATIONS SUBJECT TO WAVE ACTION

Riprap installations subject to wave action, typically for tidal bridges, should be designed using the guidelines of the Corps of Engineers as set forth in Reference 12.

11D.4 REFERENCES

1. NTSB, 1988, "Collapse of the New York Thruway (I-90) Bridge over the Schoharie, Creek, Near Amsterdam, New York, April 5, 1987," NTSB/HAR-88/02, NTSB, Washington, D.C.
2. RCI (Ayres Associates) and Colorado State University, 1987, "Hydraulic, Erosion, and Channel Stability Analysis of the Schoharie Creek Bridge Failure, New York," for NTSB and NY Thruway Authority, Fort Collins, CO.
3. Richardson, E.V. and S.R. Davis, 2001, "Evaluating Scour at Bridges," Hydraulic Engineering Circular 18, Fourth Edition, FHWA NHI 01-001, Federal Highway Administration, U.S. Department of Transportation, Washington, D.C.
4. Richardson, E.V., D.B. Simons, and P.F. Lagasse, 2001, "River Engineering for Highway Encroachments - Highways in the River Environment," Report FHWA NHI 01-004, Federal Highway Administration, Hydraulic Design Series NO. 6, Washington, D.C.
5. Parola, A.C., Jr., 1991, "The Stability of Riprap Used to Protect Bridge Piers," FHWA-RD-91-063, U.S. Department of Transportation, Washington, D.C., July.
6. Parker, G., C. Toro-Escobar, and R.L. Voight, Jr., 1998, "Countermeasures to Protect Bridge Piers From Scour," User's Guide, Vol. 1, prepared for National Cooperative Highway Research Program, Transportation Research Board, National Research Council, NCHRP Project 24-7, St. Anthony Falls Laboratory, University of Minnesota, Minneapolis, MN (revised 7/1/99).
7. Parker, G., C. Toro-Escobar, and R.L. Voight, Jr., 1998, "Countermeasures to Protect Bridge Piers from Scour," Final Report, Vol. 2, prepared for National Cooperative Highway Research Program, Transportation Research Board, National Research Council, NCHRP Project 24-7, St. Anthony Falls Laboratory, University of Minnesota, Minneapolis, MN.
8. Pagán-Ortiz, Jorge E., 1991, "Stability of Rock Riprap for Protection at the Toe of Abutments Located at the Floodplain," FHWA Research Report No. FHWA-RD-91-057, U.S. Department of Transportation, Washington, D.C.
9. Atayee, A. Tamin, 1993, "Study of Riprap as Scour Protection for Spill-through Abutment," presented at the 72nd Annual TRB meeting in Washington, D.C., January.
10. Kilgore, Roger T., 1993, "HEC-18 Guidance for Abutment Riprap Design," unpublished internal correspondence to FHWA, January.
11. Atayee, A. Tamin, Jorge E. Pagán-Ortiz, J.S. Jones, and R.T. Kilgore, 1993, "A Study of Riprap as a Scour Protection for Spill-through Abutments," ASCE Hydraulic Conference, San Francisco, CA.
12. Design of Coastal Revetments, Seawalls and Bulkheads, US Army Corps of Engineers, EM1110-2-1614, 30 June, 1995.

ATTACHMENT 1

DETAILS OF TYPICAL RIPRAP INSTALLATIONS AT PIERS AND ABUTMENTS

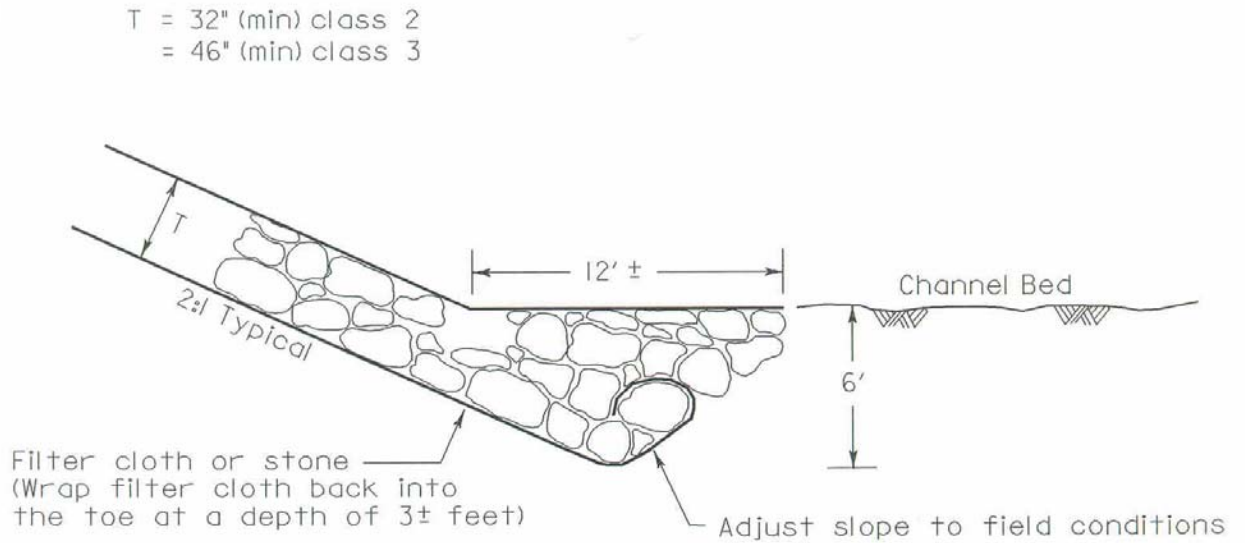

Figure 1
Typical Riprap Blanket and Toe Detail
(Not to Scale)

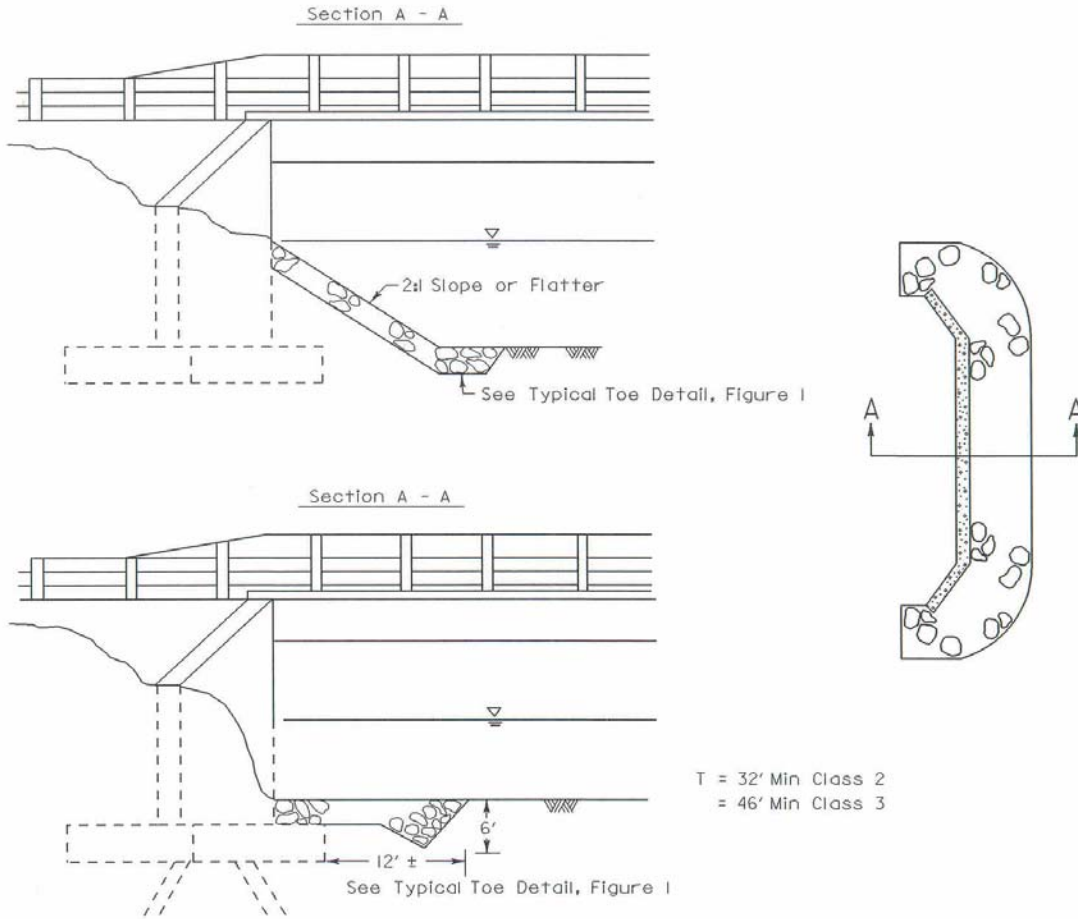

Figure 2
Abutment Near Channel Bank
 (Not to Scale)

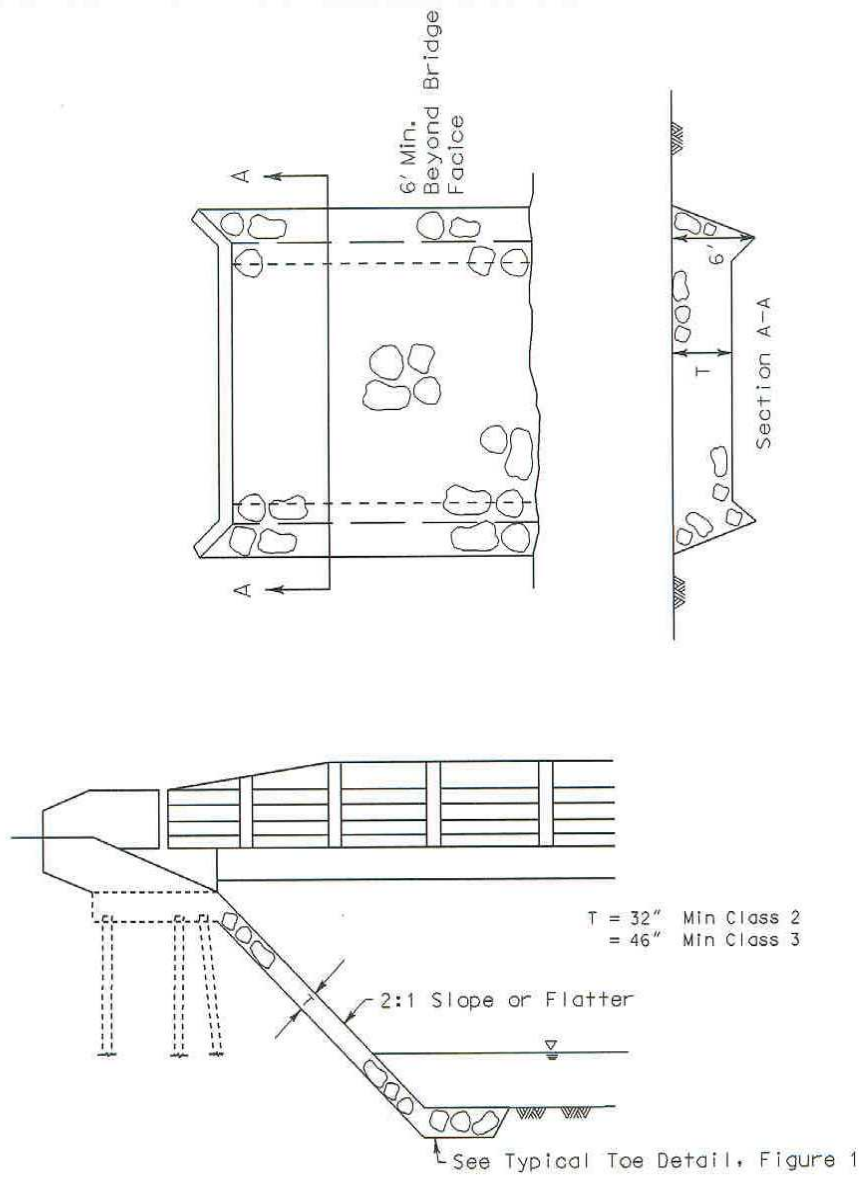
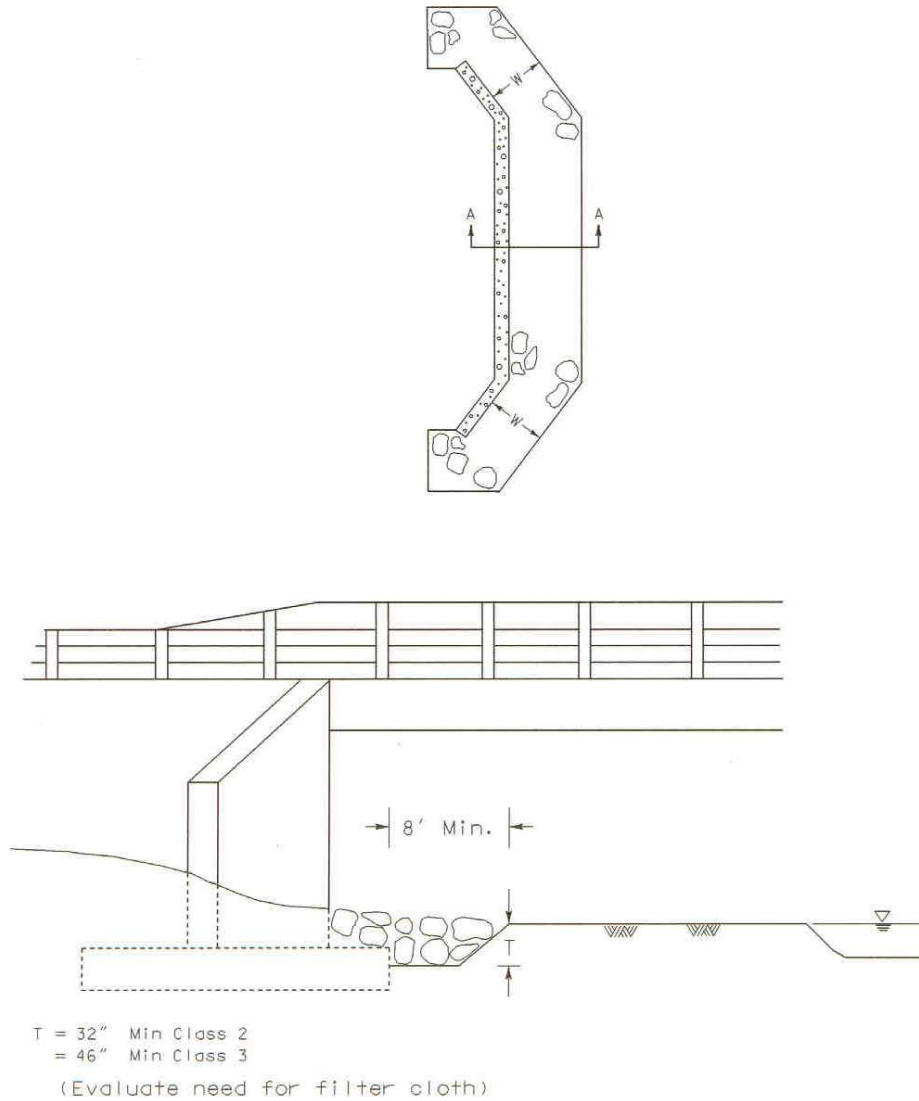
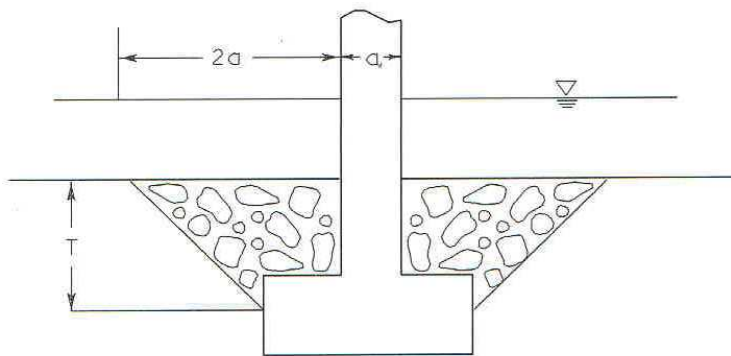
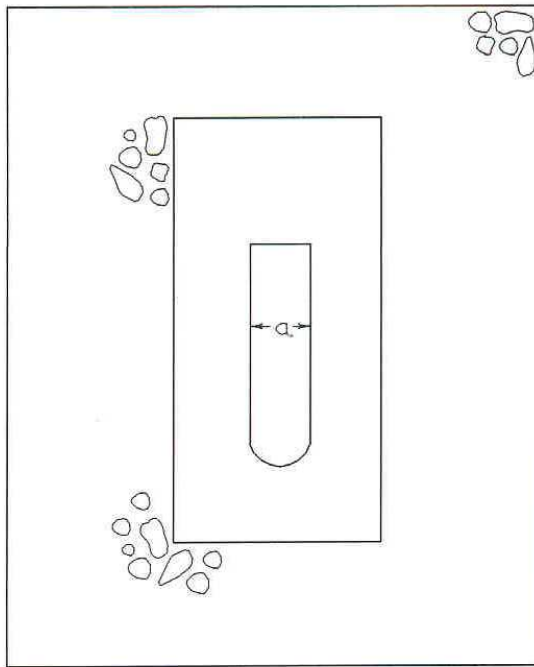

Figure 3
Abutment Near Top of High Channel Bank
 (Not to Scale)



Section A-A

Figure 4
Abutment on Flood Plain Set Well Back from Channel Bank with Low Flow
Depths and Velocities for Worst Case Scour Conditions
 (May consider use of Class 1 riprap for this condition)
 (Not to Scale)



T = Contraction scour depth or 6 feet, which ever is deeper
 (Evaluate need for filter cloth)

Figure 5
Scour Countermeasure at Pier
 (Not to Scale)

(Piers should be designed to be stable for expected worst-case scour conditions without reliance on scour countermeasures. Where additional scour protection is desired, such protection should be related to the site conditions, but would normally be expected to fall within the limits depicted in Figure 5.)

ATTACHMENT 2

EXCERPTS FROM FHWA HEC-23 DESIGN GUIDELINE 8 ROCK RIPRAP AT PIERS AND ABUTMENTS

8.1 INTRODUCTION

The Engineer is encouraged to obtain HEC-23 and read Design Guideline 8 in its entirety. The FHWA continues to evaluate how best to design rock riprap at bridge piers and abutments. Present knowledge is based on research conducted under laboratory conditions with little field verification, particularly for piers. Flow turbulence and velocities around a pier are of sufficient magnitude that large rocks move over time. Bridges have been lost (Schoharie Creek bridge) due to the removal of riprap at piers resulting from turbulence and high velocity flow. Usually this does not happen during one storm, but is the result of the cumulative effect of a sequence of high flows. **Therefore, if rock riprap is placed as scour protection around a pier, the bridge should be monitored and inspected during and after each high flow event to insure that the riprap is stable.**

8.3 SIZING ROCK RIPRAP AT PIERS

As a countermeasure for scour at piers for existing bridges, riprap can reduce the risk of failure and in some cases could make a bridge safe from scour (see HEC-18, Appendix J for additional guidance.⁽³⁾ Riprap is not recommended as a pier scour countermeasure for new bridges. Determine the D_{50} size of the riprap using the rearranged Isbash equation^(4,5) to solve for stone diameter (in meters (ft), for fresh water):

$$D_{50} = \frac{0.692 (KV)^2}{(S_s - 1)2g}$$

(8.1)

where:

D_{50}	=	median stone diameter, m (ft)
K	=	coefficient for pier shape
V	=	velocity on pier, m/s (ft/s)
S_s	=	specific gravity of riprap (normally 2.65)
G	=	9.81 m/s ² (32.2 ft/s ²)
K	=	1.5 for round-nose pier
K	=	1.7 for rectangular pier

To determine V multiply the average channel velocity (Q/A) by a coefficient that ranges from 0.9 for a pier near the bank in a straight uniform reach of the stream to 1.7 for a pier in the main current of flow around a sharp bend.

1. Provide a riprap mat width which extends horizontally at least two times the pier width, measured from the pier face.
2. Place the top of a riprap mat at the same elevation as the streambed. Placing the bottom of a riprap mat on top of the streambed is discouraged. In all cases where riprap is used for scour control, the bridge must be monitored during and inspected after high flows.

It is important to note that it is a disadvantage to bury riprap so that the top of the mat is below the streambed because inspectors have difficulty determining if some or all of the riprap has been removed. Therefore, it is recommended to place the top of a riprap mat at the same elevation as the streambed.

- a. The thickness of the riprap mat should be three stone diameters (D_{50}) or more. In general, the bottom of the riprap blanket should be placed at or below the computed contraction scour depth.
- b. In some conditions, place the riprap on a geotextile or a gravel filter. However, if a well-graded riprap is used, a filter may not be needed. In some flow conditions it may not be possible to place a filter or if the riprap is buried in the bed a filter may not be needed.
- c. The maximum size rock should be no greater than twice the D_{50} size.

8.4 LABORATORY TESTING OF PIER RIPRAP

National Cooperative Highway Research Program (NCHRP) Project 24-7, "Countermeasures to Protect Bridge Piers from Scour," was completed in December 1998.^(6,7) This project evaluated alternatives to standard riprap installations as pier scour countermeasures, as well as various riprap configurations, including:

- X Riprap with prior excavation and with geotextile or granular filter
- X Riprap without prior excavation but with geotextile or granular filter
- X Riprap without prior excavation, without geotextile or granular filter

Based on laboratory testing, this study concluded that under flood conditions in sand bed streams, riprap placed in the absence of a geotextile or granular filter layer would gradually settle and lose effectiveness over time, even under conditions for which the riprap is never directly mobilized by the flow. This settling is due to deformation and leaching of sand associated with the passage of bedforms. Riprap performance can be considerably improved with the use of a geotextile, especially if the geotextile is sealed to the pier.⁽⁷⁾ Design suggestions are provided in a User's Guide for various riprap configurations.⁽⁶⁾

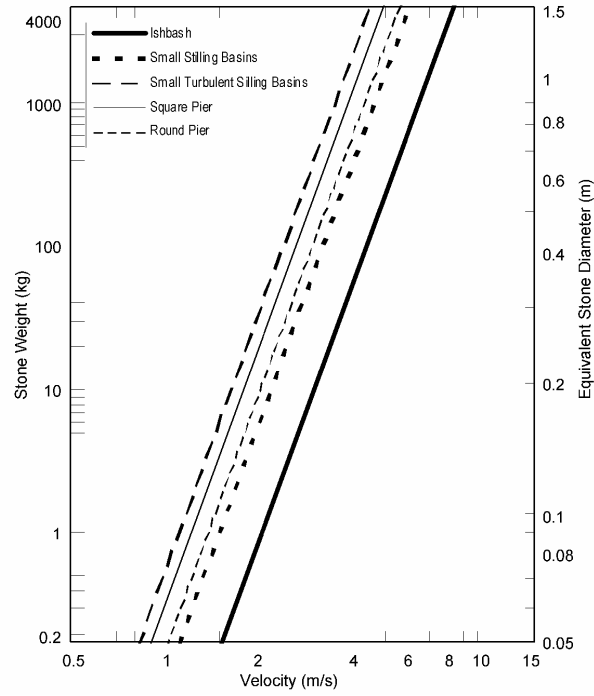

(SI Units)

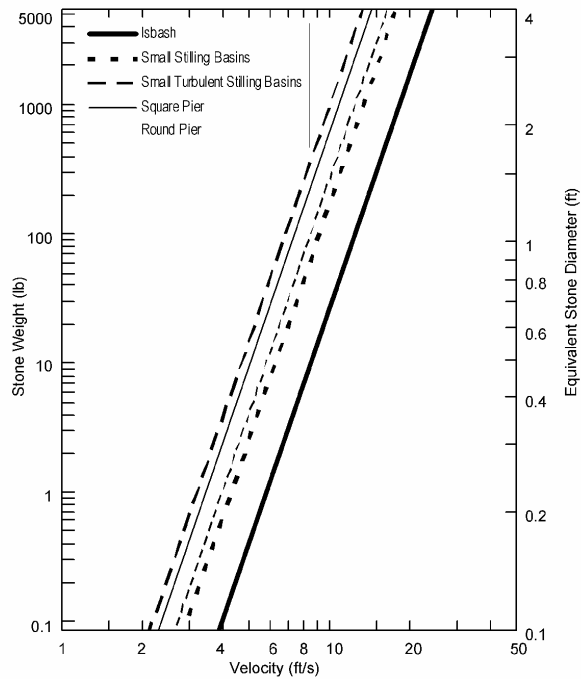

(English Units)

Figure 8.3. Effect of turbulence intensity on rock size using the Isbash approach.

8.7 SIZING ROCK RIPRAP AT ABUTMENTS

The FHWA conducted two research studies in a hydraulic flume to determine equations for sizing rock riprap for protecting abutments from scour.^(8,9) The first study investigated vertical wall and spill-through abutments which encroached 28 and 56 percent on the floodplain, respectively. The second study investigated spill-through abutments which encroached on a floodplain with an adjacent main channel (Figure 8.6). Encroachment varied from the largest encroachment used in the first study to a full encroachment to the edge of main channel bank. For spill-through abutments in both studies, the rock riprap consistently failed at the toe downstream of the abutment centerline (Figure 8.7). For vertical wall abutments, the first study consistently indicated failure of the rock riprap at the toe upstream of the centerline of the abutment.

Field observations and laboratory studies reported in HDS 6⁽⁴⁾ indicate that with large overbank flow or large drawdown through a bridge opening that scour holes develop on the side slopes of spill-through abutments and the scour can be at the upstream corner of the abutment. In addition, flow separation can occur at the downstream side of a bridge (either with vertical wall or spill-through abutments). This flow separation causes vertical vortices which erode the approach embankment and the downstream corner of the abutment.

For Froude Numbers $(V/(gy)^{1/2}) < 0.80$, the recommended design equation for sizing rock riprap for spill-through and vertical wall abutments is in the form of the Isbash relationship:

$$\frac{D_{50}}{y} = \frac{K}{(S_s - 1)} \left[\frac{V^2}{gy} \right] \quad (8.2)$$

where:

- D_{50} = median stone diameter, m (ft)
- V = Characteristic average velocity in the contracted section (explained below), m/s (ft/s)
- S_s = specific gravity of rock riprap
- G = gravitational acceleration, 9.81 m/s² (32.2 ft/s²)
- Y = depth of flow in the contracted bridge opening, m (ft)
- K = 0.89 for a spill-through abutment
1.02 for a vertical wall abutment

For Froude Numbers >0.80 , Equation 8.3 is recommended:⁽¹⁰⁾

$$\frac{D_{50}}{y} = \frac{K}{(S_s - 1)} \left[\frac{V^2}{gy} \right]^{0.14}$$

(8.3)

where:

- K = 0.61 for spill-through abutments
- = 0.69 for vertical wall abutments

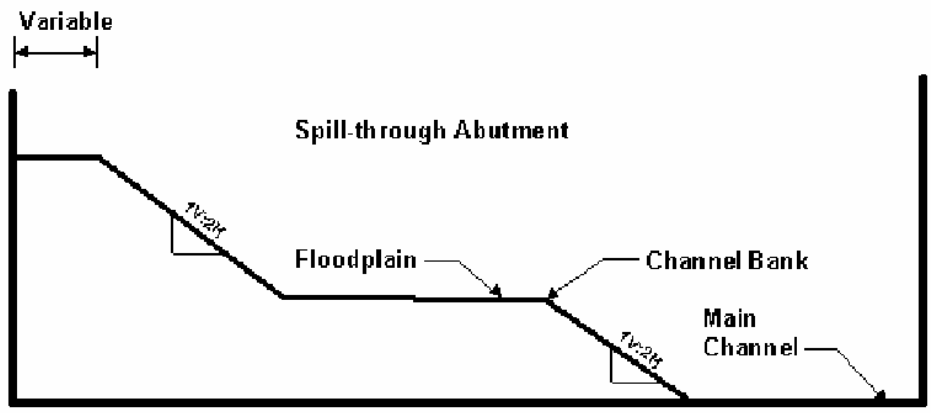

Figure 8.6. Section view of a typical setup of spill-through abutment on a floodplain with adjacent main channel.

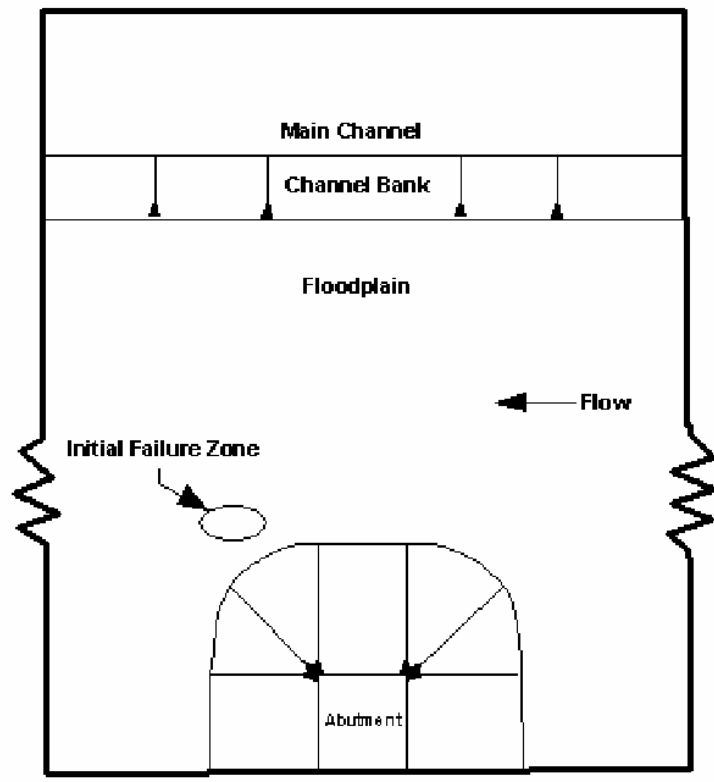

Figure 8.7. Plan view of the location of initial failure zone of rock riprap for spill-through abutment.

In both equations, the coefficient K, is a velocity multiplier to account for the apparent local acceleration of flow at the point of rock riprap failure. Both of these equations are envelope relationships that were forced to over predict 90 percent of the laboratory data.

A recommended procedure for selecting the characteristic average velocity is as follows:

1. Determine the set-back ratio (SBR) of each abutment. SBR is the ratio of the set-back length to channel flow depth. The set-back length is the distance from the near edge of the main channel to the toe of abutment.

$$\text{SBR} = \text{Set-back length/average channel flow depth}$$

- a. If SBR is less than 5 for both abutments (Figure 8.8), compute a characteristic average velocity, Q/A , based on the entire contracted area through the bridge opening. This includes the total upstream flow, exclusive of that which overtops the roadway. The WSPRO average velocity through the bridge opening is also appropriate for this step.
 - b. If SBR is greater than 5 for an abutment (Figure 8.9), compute a characteristic average velocity, Q/A , for the respective overbank flow only. Assume that the entire respective overbank flow stays in the overbank section through the bridge opening. This velocity can be approximated by a hand calculation using the cumulative flow areas in the overbank section from WSPRO, or from a special WSPRO run using an imaginary wall along the bank line.
 - c. If SBR for an abutment is less than 5 and SBR for the other abutment at the same site is more than 5 (Figure 8.10), a characteristic average velocity determined from Step 1a for the abutment with SBR less than 5 may be unrealistically low. This would, of course, depend upon the opposite overbank discharge as well as how far the other abutment is set back. For this case, the characteristic average velocity for the abutment with SBR less than 5 should be based on the flow area limited by the boundary of that abutment and an imaginary wall located on the opposite channel bank. The appropriate discharge is bounded by this imaginary wall and the outer edge of the floodplain associated with that abutment.
2. Compute rock riprap size from Equations 8.2 or 8.3, based on the Froude Number limitation for these equations.
 3. Determine extent of rock riprap.
 - a. The apron at the toe of the abutment should extend along the entire length of the abutment toe, around the curved portions of the abutment to the point of tangency with the plane of the embankment slopes.
 - b. *The apron should extend from the toe of the abutment into the bridge waterway a distance equal to twice the flow depth* in the overbank area near the embankment, but need not exceed 7.5 m (25 ft) (Figure 8.11).⁽¹¹⁾*
*** Please note that SHA uses different criteria to determine the extent of the riprap blanket. See Attachment 1**

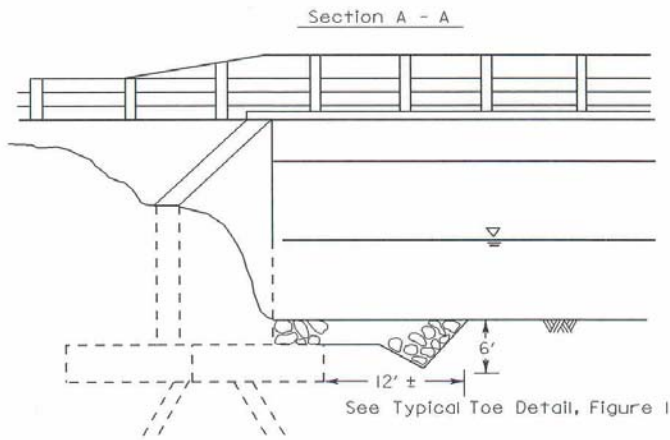
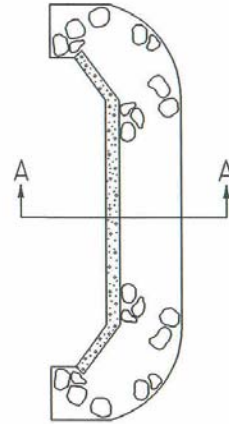
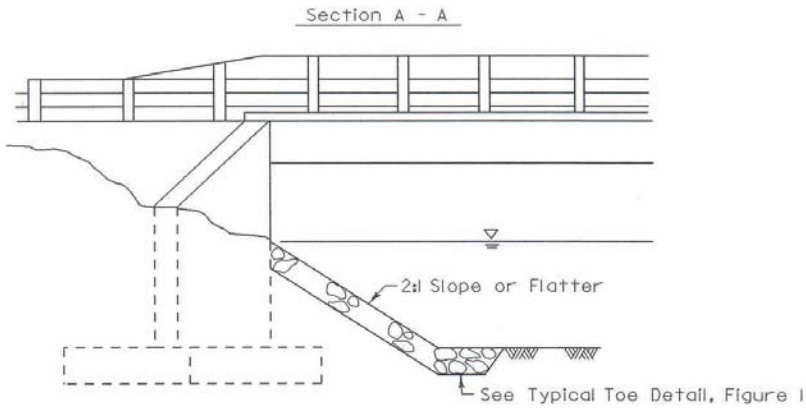

T = 32' Min Class 2
 = 46' Min Class 3

